

SCIWIL	No.:				
	Name:	SW900VA			
Issued on:	27 th May, 2023	Version:	A/0	Page 1 of 14	
Written By:	Zhang Pei	Rev.:	Liu Jian	Apprv.:	Luo Zhenrong

USERS GUIDE

SW900-VA



Changzhou Sciwil E-Mobility Technology Co., Ltd.

9th Huashan Road, Changzhou, Jiangsu, China- 213022

Fax: +86 519-85602675 Tel: +86 519-85600675

Contents

Introduction	1
1. Product Name and Model	2
2. Specifications	2
3. Exterior Look and Size	2
4. Cable Connection	3
5. Assembly	4
6. Functions	4
7. Operation Guide	5
7.1 Riding Interface	5
7.2 Setting Interface	6
7.3 Error Report Interface	6
7.4 Key Pad	6
8. General Operations	7
8.1 Switch On/Off	7
8.2 Assist Level	7
8.3 Interface Switching.....	7
8.3.1 Speed Switching	9
8.3.2 Distance Switching	9
8.4 Front Light On/Off	9
8.5 6km/h Walk Assist Mode	9
9 Introduction of Setting Interface	10
10. Settings	10
10.0 Factory Reset (optional)	10

10.1 Backlight Brightness	10
10.2 System Unit	10
10.3 Voltage Level	10
10.4 Auto-Off Interval	10
10.5 Assist Level Range	11
10.6 Wheel Size	11
10.7 Magnet Steel Number for Speed Test	11
10.8 Speed Limit	11
10.9 Start Mode	11
10.10 Drive Mode	11
10.11 PAS Sensor Type	11
10.12 PAS Start Strength	11
10.13 Magnet Steel	11
10.14 Controller Current Limit	11
10.15 Display Low Voltage Level	11
10.16 Clear Distance	12
10.17 Cruise (optional)	12
11. Error Code	12
12. Serial Code	13
13. Safety Notes	14
14. Quality and Warranty	15
15. Version	15

Introduction

Congratulations on purchasing your e-bike smart display. Before use, please read through this manual. It is important to acknowledge all the **WARNINGS, SAFETY NOTES AND INSTRUCTIONS**. This manual will walk you through assembly, settings and operations of Sciwil display products in easy steps, to facilitate operations on your e-bike.

1. Product Name and Model

Product Name: E-Bike Display

Product Model: SW-900

2. Specifications

- ① Working Voltage: DC 24V/36V/48V/52V/60V/72V
- ② Rated Working Current: 12mA
- ③ Leakage current: <1uA
- ④ Screen Size: 3.6 " LCD
- ⑤ Communication Type: UART (by default)
- ⑥ Working Temperature: -20°C ~ 70°C
- ⑦ Storage Temperature: -30°C ~ 80°C
- ⑧ Waterproof Rating: IPX6

3. Exterior Look and Size

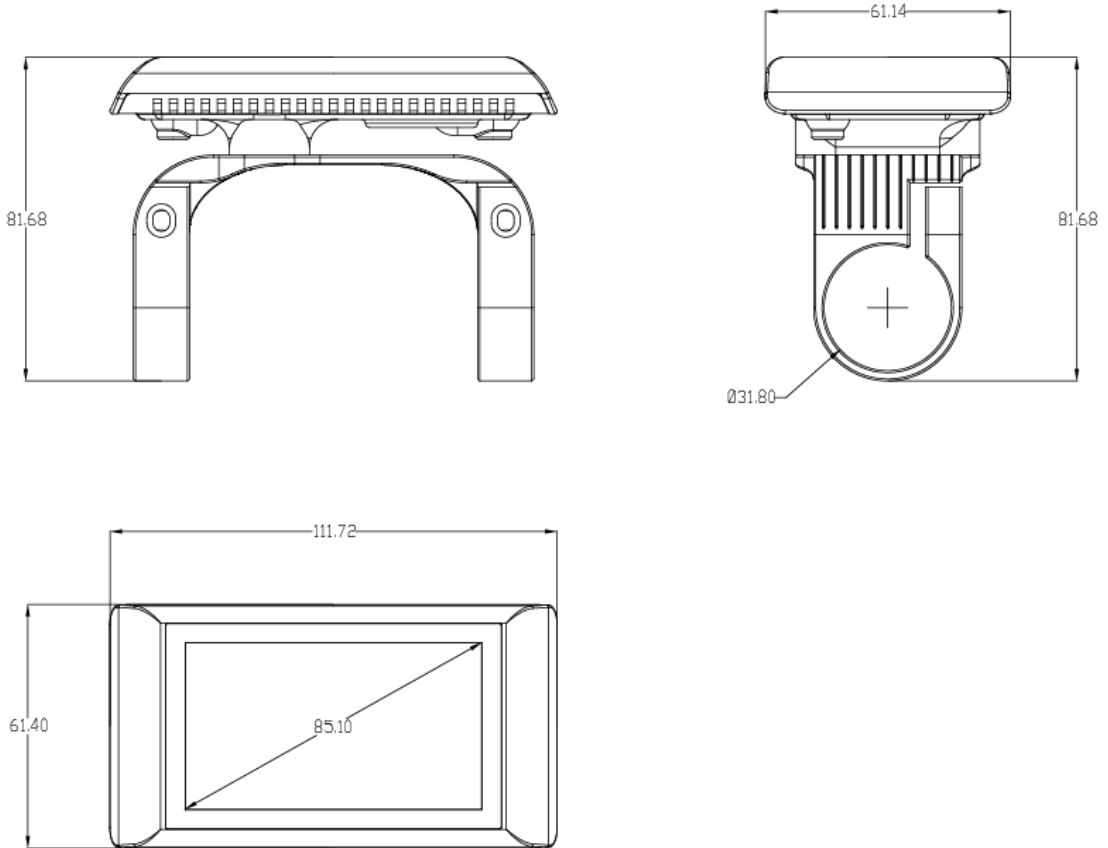

4. Cable Connection

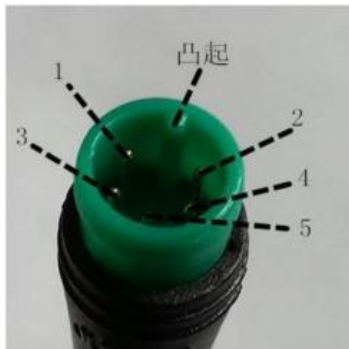

Display to Controller
Waterproof Type (BMING)



Controller to Display
Waterproof Type (BMING)

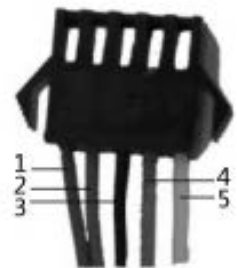

Controller Connector
Regular Type

Standard Cable Connector Diagram

Sequence No.	Wire Color	Functions
1	Red (VCC)	Display Power Cable
2	Blue (K)	Controller Power Cable
3	Black (GND)	Display Ground Cable
4	Green (RX)	Display Data Receiving Wire
5	Yellow (TX)	Display Data Sending Wire

5. Assembly

① Open the holder ring/rubber spacer of the display and fix the display on the handlebar, adjust it to a proper facing angle. Use a M3 Hex Wrench to fix and tighten the screws. Standard fixing torque: **0.8N•m**.

*Damage due to extra fixing torque is not covered by warranty.

② Make sure your e-bike is powered off, then plug the connector on the display to the connector on the controller (bus) to finish standard assembly.

6. Functions

- ① Simple key pad for easy & clear operation
- ② Boot password (optional)
- ③ System unit switch (km/h or mph)
- ④ Speed display:
real-time speed (SPEED), max speed (MAX), average speed (AVG)
- ⑤ Assist Level Control
- ⑥ Battery indication: battery capacity, low voltage indication, BMS info display
- ⑦ Front light indication: front light status supported by controller

- ⑧ Distance: single-trip distance (TRIP), total travel distance (ODO)
- ⑨ Riding Time: TRIP TIME
- ⑩ Communication port connection: for system maintenance and specs settings
- ⑪ Walk assist mode
- ⑫ Error code indication

7. Operation Guide

7.1 Riding Interface



- ① Real-Time Speed (RT SPEED): current riding speed
- ② Average Speed (AVG SPEED): average riding speed
- ③ Maximum Speed (MAX SPEED): the max speed during ride
- ④ Total Travel Distance (ODO): total riding distance, max value 99999.9
- ⑤ Assist Level and Walk Mode: Assist Level 3/5/9 levels, can be changed.

- ⑥ Current Speed and Unit: current riding speed, unit: km/h or mph
- ⑦ Single-Trip Distance and Unit: with accuracy of 0.1, max value 99999.9
- ⑧ Battery Indication: the current battery level
- ⑨ Front Light Indication: shows icon when the front light is turned on by display
- ⑩ Power Indication: real-time motor output power

7.2 Setting Interface



7.3 Error Report Interface

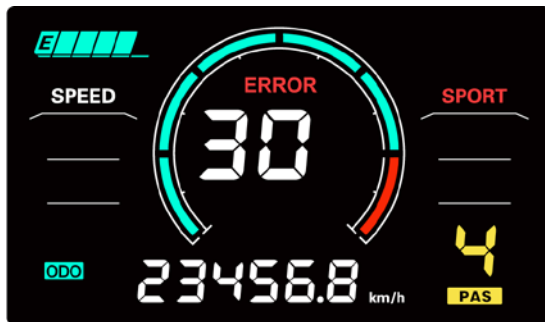

7.4 Key Pad

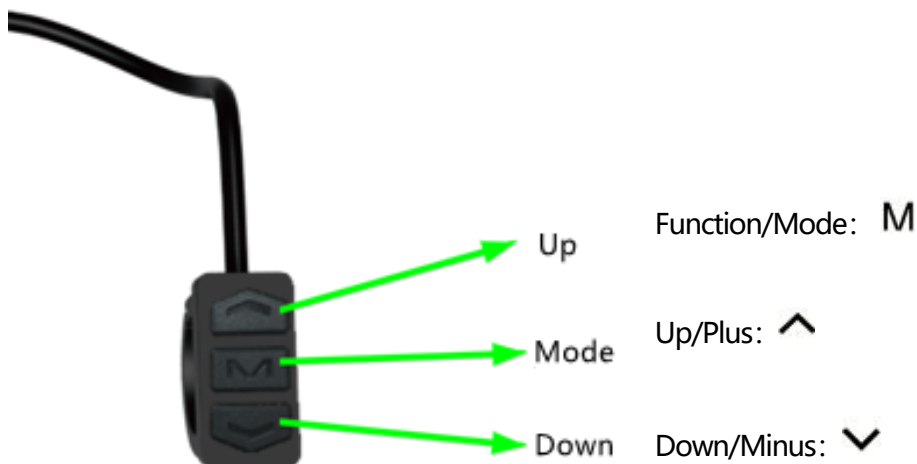

8. General Operations



8.1 Switch On/Off

Keep the display connected with controller, press and hold Mode **M** for 2s to turn on the display. The display will show complete interface first before entering into riding interface.

When the display is on, press and hold Mode **M** for 2s to turn off the display.

The display will automatically turn off if no operation happened within 5min (the auto-off interval can be adjusted in the Settings interface).

8.2 Assist Level

Press Up  or Down  to toggle assist levels. Generally, there are 3/5/9 levels available. The display shows 1 as default start level, level 0 means no pedal assist output. (the selection interface of assist level see below)



Level0



Level1



Level2



Level3



Level4



Level5



Walk Assist Mode

8.3 Interface Switching

Press Mode **M** to switch display info among single-trip distance, riding time, total distance. Toggle items: single-trip distance (TRIP)-> riding time (TRIP TIME) -> total distance (ODO).

Mode switching interface as follows:



8.3.1 Speed Switching

Press and hold Mode **M** and Down **▼** to switch between Average Speed and Max Speed. Toggle items: Current Speed -> Average Speed (AVG) -> Max Speed (MAX).

Speed switching interface as follows:



8.3.2 Distance Switching



8.4 Front Light On/Off

For display-controlled front light, press and hold Up **▲** for 1s and the front light will be on and the dipped beam icon will be shown in the riding interface. Press and hold Up **▲** for 1s the front light will be off, the dipped beam light icon is also off.

8.5 6km/h Walk Assist Mode



Press and hold Down **▼** for 2s to enter 6km/h walk assist mode, the current speed shows in the Assist Level section. Release Down **▼** to exit walk assist mode. Walk mode switching interface as follow (under walk mode).







***This function may not be supported by some controllers.**

9. Introduction of Setting Interface

Introduction of Setting Operations

1. Press and hold Up  and Down  together for 2s to enter the settings interface. You may set Working Voltage, Wheel Size (inch), Magnetic Steel Number, Speed Limit ect. Please refer to Settings P01-P17 for parameters available.

Under the setting interface, you may press Up  and Down  to increase/decrease the setting value. The value will blink after being modified. Press Mode **M** to switch to the next item and save the previous changes automatically.

2. Press and hold Up  and Down  together for 2s again to save the adjusted value and exit the settings interface. Otherwise system will automatically exit and save values after 10 seconds.

10. Settings

P01: Backlight Brightness (1: darkest; 3: brightest)

P02: Mileage Unit (0: km; 1: mile)

P03: Voltage Class (24V / 36V / 48V / 60V / 72V)

P04: Auto-Off Time

(0: never, other value means time interval for display auto-off) Unit: minute

P05: Pedal Assist Level

0/3 Gear Mode: Gear 1-2V, Gear 2-3V, Gear 3-4V

1/5 Gear Mode: Gear 1-2V, Gear 2-2.5V, Gear 3-4V, Gear 4-3.5V, Gear 5-4V

P06: Wheel Size (Unit: inch Precision: 0.1)

P07: Motor Magnets Number (for Speed Test; Range: 1-100)

P08: Speed Limit Range: 0-50km/h, no speed limit if set to 50)

1. Communications status (controller-controlled)

The driving speed will be kept constant as the limited value.

Error Value: ± 1 km/h (applicable to both the PAS/throttle mode)

Note: The above-mentioned values are measured by metric unit (kilometers).

When the measuring unit is set to imperial unit (mile), the speed displayed on the panel will be automatically switched to corresponding imperial unit, however the speed limit value in the imperial unit interface won't change accordingly.

P09: Direct Start / Kick-to-Start Setting

0: Direct Start

1: Kick-to-Start

P10: Drive Mode Setting

0: Pedal Assist – The specific gear of the assist drive decides the assist power value. In this status the throttle does not work.

1: Electric Drive – The vehicle is driven by the throttle. In this status the power gear does not work.

2: Pedal Assist + Electric Drive – Electric drive does not work in direct-start status.

P11: Pedal Assist Sensitivity (Range: 1-24)

P12: Pedal Assist Starting Intensity (Range: 0-5)

P13: Magnets Number in Pedal Assist Sensor (5 / 8 / 12pcs)

P14: Current Limit Value (12A by default; Range: 1-20A)

P15: Unspecified

P16: ODO Clearance

Press and hold the up key for 5 seconds and ODO distance will be cleared.

P17: Cruise (0: without cruise function, 1: with cruise function)

11. Error Code

The display can report error codes of the electric vehicle. Error codes will be shown when the display detects corresponding error/failure. The interface is as follows:

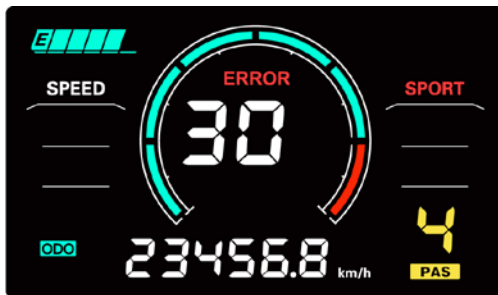

Error Code Table

Error Code (decimal)	Status	Note
E00	Normal	
E03	Brake Engaged	
E05	Throttle Failure	
E06	Low Voltage Protection	
E07	Over Voltage Protection	
E08	Motor Hall Signal Error	
E09	Motor Phase Error	
E16	Controller Error	
E23	Front Light Error	
E27	Controller Over Current Error	
E30	Communications Error	

12. Serial Code

Each Sciwil display product bears a unique Serial Code on the back shell



(as shown in the photo below): 192 2 1 210603011

Explanation to the above Serial Code:

192: Customer Code

2: Protocol Code

1: Program can be overridden (0 means can not be overridden)

210603011: P.O. (purchase order number)

13. Safety Notes

PLEASE TAKE CAUTION WHEN USE, DO NOT PLUG OR UNPLUG THE DISPLAY WHILE YOUR E-BIKE IS POWERED ON.



AVOID CLASHES OR BUMPS TO THE DISPLAY.



AVOID USING IN HEAVY RAINS, SNOWS OR LONG EXPOSURE TO STRONG SUNLIGHT. DO NOT TEAR THE WATER-PROOF FILM ON THE SURFACE OF THE SCREEN, OTHERWISE THE WATER-TIGHT PERFORMANCE OF THE PRODUCT MAY BE DEGRADED.



DO NOT PLUG OR UNPLUG THE DISPLAY WHILE THE SYSTEM IS POWERED ON. UNAUTHORIZED ADJUSTMENT TO DEFAULT SETTINGS IS NOT SUGGESTED, OTHERWISE NORMAL USE OF YOUR E-BIKE CAN NOT BE GUARANTEED.



WHEN THE DISPLAY PRODUCT DOES NOT WORK PROPERLY, PLEASE SEND THE IT FOR AUTHORIZED REPAIR IN TIME.

14. Quality and Warranty

8.1 Warranty Term

In compliance with local laws, Sciwil provides limited warranty period covering 24 months after the date of manufacturing (as indicated by the serial number), applies to quality issues during normal operations.

The limited warranty shall not be transferred to a third party other than as specified in the agreement with Sciwil.

Other situations may be covered, depending on the agreement between Sciwil and the buyer.

8.2 Warranty Exclusions:

1. Sciwil products that have been opened, modified or repaired without authorization.
2. Damage on the connectors.
3. Damage to the surface after leaving factory, including shell, screen, buttons, or other appearance parts.
4. Damage to wiring and cables after leaving factory, including breaks and exterior scratch.
5. Damage or loss due to force majeure (e.g. fire or earthquake) or natural disaster (e.g. lightning).
6. Out of the warranty period.

15. Version

This display user manual is in compliance with the general software version (A/0) of Changzhou Sciwil E-Mobility Technology Co., Ltd. There are chances that display products on some e-bikes may have a different software version, which should be subject to the actual version in use.